

# 6FM134D-X 12V 134Ah(20hr)

The rechargeable batteries are lead-lead dioxide systems. The dilute sulfuric acid electrolyte is absorbed by separators and plates and thus immobilized. Should the battery be accidentally overcharged producing hydrogen and oxygen, special one-way valves allow the gases to escape thus avoiding excessive pressure build-up. Otherwise, the battery is completely sealed and is, therefore, maintenance-free, leak proof and usable in any position.

## Battery Construction

Component	Positive plate	Negative plate	Container	Cover	Safety valve	Terminal	Separator	Electrolyte
Raw material	Lead dioxide	Lead	ABS	ABS	Rubber	Copper	Fiberglass	Sulfuric acid

## General Features

- Absorbent Glass Mat (AGM) technology for efficient gas recombination of up to 99% and freedom from electrolyte maintenance or water adding.
- Not restricted for air transport-complies with IATA/ICAO Special Provision A67.
- UL-recognized component.
- Can be mounted in any orientation.
- Computer designed lead, calcium tin alloy grid for high power density.
- Long service life, float or cyclic applications.
- Maintenance-free operation.
- Low self discharge.

## Dimensions and Weight

Length(mm / inch)	341 / 13.4
Width(mm / inch)	173 / 6.81
Height(mm / inch)	283 / 11.1
Total Height(mm / inch)	287 / 11.3
Approx. Weight(Kg / lbs)	40 / 88.2

\* Weight deviation: ± 3%

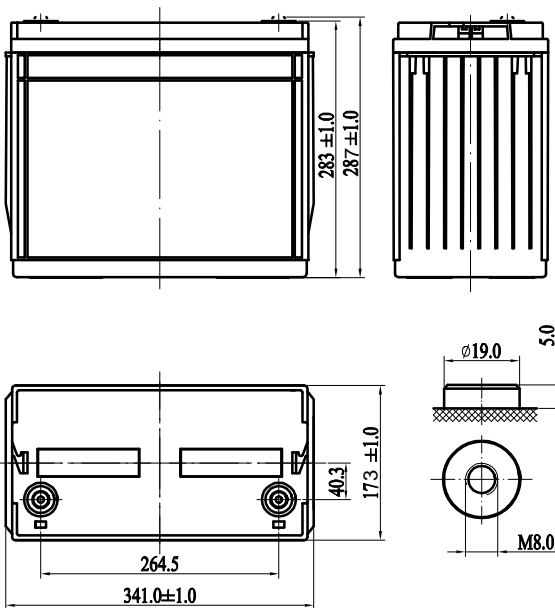

## Performance Characteristics

Nominal Voltage	12V
Number of cell	6
Design Life	10 years
Nominal Capacity 77°F(25°C)	
20 hour rate (6.7A, 10.5V)	134Ah
10 hour rate (13.1A, 10.5V)	131Ah
5 hour rate (22.1A, 10.5V)	110.5Ah
1 hour rate (83.6A, 9.6V)	83.6Ah
Internal Resistance	
Fully Charged battery 77°F(25°C)	≤ 5.0mOhms
Self-Discharge	
3% of capacity declined per month at 20°C(average)	
Operating Temperature Range	
Discharge	-20~60°C
Charge	-10~60°C
Storage	-20~60°C
Max. Discharge Current 77°F(25°C)	950A(5s)
Short Circuit Current	2250A
Charge Methods: Constant Voltage Charge 77°F(25°C)	
Cycle use	2.40-2.45VPC
Maximum charging current	40.2A
Temperature compensation	-30mV/°C
Temperature compensation	-20mV/°C

## Discharge Constant Current (Amperes at 77°F25°C)

End Point Volts/Cell	10min	15min	30min	1h	3h	5h	10h	20h
1.60V	294	239	135	83.6	34.3	23.3	13.3	6.80
1.65V	278	230	131	83.0	33.5	23.0	13.2	6.78
1.70V	263	220	127	81.3	32.8	22.5	13.1	6.75
1.75V	247	210	122	78.9	32.1	22.1	13.1	6.70
1.80V	232	201	119	76.3	31.2	21.7	13.0	6.67

## Discharge Constant Power (Watts at 77°F25°C)

End Point Volts/Cell	10min	15min	30min	45min	1h	2h	3h	5h
1.60V	531	423	256	181	168	92.6	66.0	45.9
1.65V	504	409	248	178	165	91.1	65.2	45.7
1.70V	478	396	242	174	163	89.4	64.4	45.3
1.75V	453	382	234	169	158	87.8	63.7	45.0
1.80V	423	369	226	166	153	86.9	62.5	44.6

(Note)The above characteristics data are average values obtained within three charge/discharge cycles not the minimum values. All data shall be changed without notice,Luxury reserves the right to explain and update the information contained hereinto.

