

6FM65GD-X 12V 65Ah(20hr)

The rechargeable batteries are lead-lead dioxide systems. The dilute sulfuric acid electrolyte is absorbed by separators and plates and thus immobilized. Should the battery be accidentally overcharged producing hydrogen and oxygen, special one-way valves allow the gases to escape thus avoiding excessive pressure build-up. Otherwise, the battery is completely sealed and is, therefore, maintenance-free, leak proof and usable in any position.

Battery Construction

| Component | Positive plate | Negative plate | Container | Cover | Safety valve | Terminal | Separator | Electrolyte |
|--------------|----------------|----------------|-----------|-------|--------------|----------|------------|---------------|
| Raw material | Lead dioxide | Lead | ABS | ABS | Rubber | Copper | Fiberglass | Sulfuric acid |

General Features

- Gel and Absorbent Glass Mat (AGM) technology for efficient gas recombination of up to 99% and freedom from electrolyte maintenance or water adding.
- Not restricted for air transport-complies with IATA/ICAO Special Provision A67.
- UL-recognized component.
- Can be mounted in any orientation.
- Computer designed lead, calcium tin alloy grid for high power density.
- Long service life, float or cyclic applications.
- Maintenance-free operation.
- Low self discharge.

Dimensions and Weight

| | |
|--------------------------|-------------|
| Length(mm / inch) | 350 / 13.78 |
| Width(mm / inch) | 167 / 6.57 |
| Height(mm / inch) | 179 / 7.05 |
| Total Height(mm / inch) | 179 / 7.05 |
| Approx. Weight(Kg / lbs) | 23.4 / 51.5 |

* Weight deviation: ± 3%

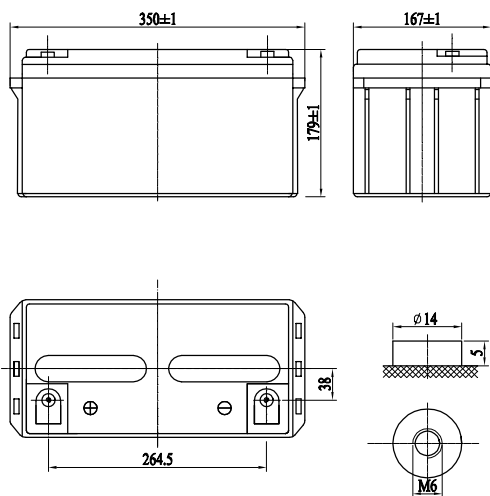

Performance Characteristics

| | |
|--|--------------|
| Nominal Voltage | 12V |
| Number of cell | 6 |
| Design Life | 10 years |
| Nominal Capacity 77°F(25°C) | |
| 20 hour rate (3.25A, 10.8V) | 65Ah |
| 10 hour rate (6.07A, 10.8V) | 60.7Ah |
| 5 hour rate (11.2A, 10.5V) | 56.0Ah |
| 1 hour rate (43.5A, 9.6V) | 43.5Ah |
| Internal Resistance | |
| Fully Charged battery 77°F(25°C) | ≤ 5.4mOhms |
| Self-Discharge | |
| 3% of capacity declined per month at 20°C(average) | |
| Operating Temperature Range | |
| Discharge | -20~60°C |
| Charge | -10~60°C |
| Storage | -20~60°C |
| Max. Discharge Current 77°F(25°C) | 650A(5s) |
| Short Circuit Current | 1700A |
| Charge Methods: Constant Voltage Charge 77°F(25°C) | |
| Cycle use | 2.40-2.45VPC |
| Maximum charging current | 19.5A |
| Temperature compensation | -30mV/°C |
| Temperature compensation | -20mV/°C |

Discharge Constant Current (Amperes at 77°F25°C)

| End Point Volts/Cell | 10min | 15min | 30min | 45min | 1h | 3h | 5h | 10h | 20h |
|----------------------|-------|-------|-------|-------|------|------|------|------|------|
| 1.60V | 154 | 121 | 68.8 | 52.0 | 43.5 | 17.5 | 12.0 | 6.25 | 3.34 |
| 1.65V | 145 | 113 | 66.3 | 51.8 | 41.3 | 16.9 | 11.6 | 6.21 | 3.32 |
| 1.70V | 138 | 111 | 64.7 | 49.1 | 40.9 | 16.7 | 11.4 | 6.17 | 3.30 |
| 1.75V | 127 | 105 | 64.6 | 48.8 | 40.3 | 16.5 | 11.2 | 6.12 | 3.28 |
| 1.80V | 115 | 97.1 | 60.3 | 46.4 | 37.7 | 16.1 | 11.0 | 6.07 | 3.25 |

Discharge Constant Power (Watts at 77°F25°C)

| End Point Volts/Cell | 10min | 15min | 30min | 45min | 1h | 2h | 3h | 5h |
|----------------------|-------|-------|-------|-------|------|------|------|------|
| 1.60V | 271 | 216 | 129 | 96.1 | 79.6 | 45.5 | 34.2 | 22.7 |
| 1.65V | 257 | 200 | 124 | 94.6 | 77.8 | 44.5 | 33.5 | 22.5 |
| 1.70V | 242 | 191 | 115 | 92.6 | 76.1 | 44.0 | 33.4 | 22.3 |
| 1.75V | 228 | 187 | 113 | 90.6 | 74.3 | 42.6 | 32.1 | 21.9 |
| 1.80V | 212 | 178 | 111 | 89.4 | 73.9 | 42.0 | 31.4 | 21.6 |

(Note)The above characteristics data are average values obtained within three charge/discharge cycles not the minimum values.

All data shall be changed without notice,Luxury reserves the right to explain and update the information contained hereinto.

Life characteristics of standby use

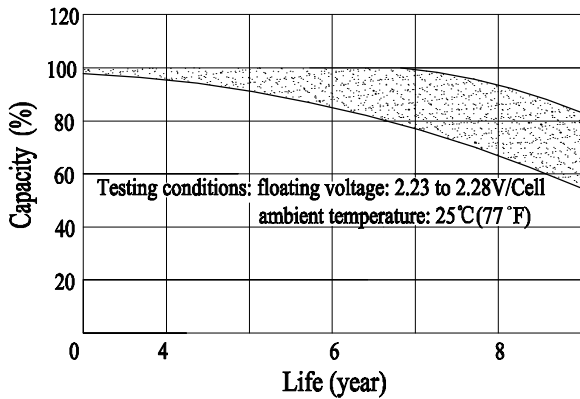

Cycle service life in relation to depth of discharge

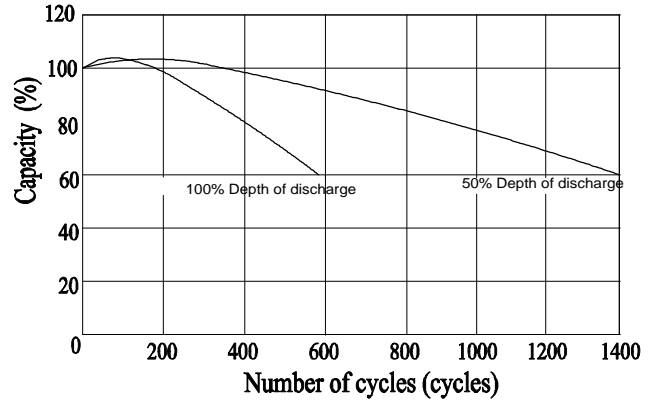

Relationship of OCV and state of charge (25°C)

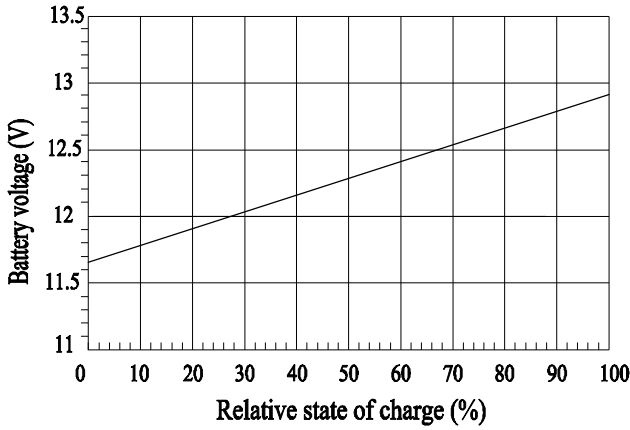

Self-discharge characteristic

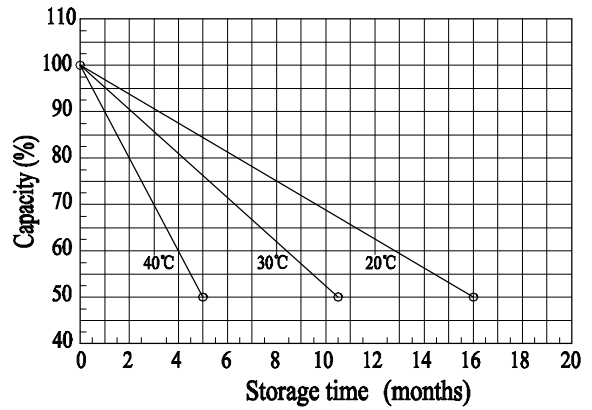

Temperature effects on float life

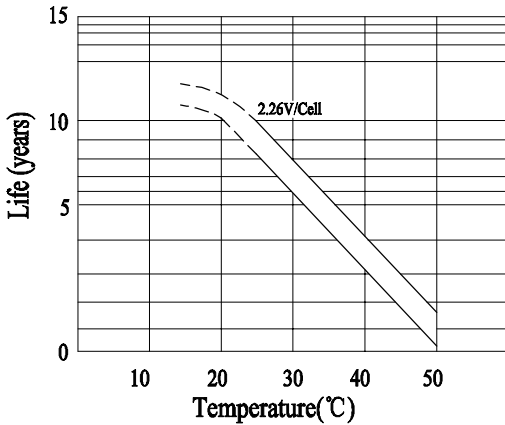

Temperature effects on capacity

