

## CG2-3000 2V 3000Ah(10hr)

Gel battery shows some distinctive advantages over flooded battery or AGM battery, such as super thermal stability, high deep discharge capability, good recovery from deep discharge, even if the battery is left discharged for three days, it will recover to 100% of capacity. With the above-mentioned advantages, the gel battery has long service life, specially suitable for motive power applications, such as golf trailer, sruubber, folklift, etc. The deep discharge cycles increased 50% as compared with the AGM battery.

### Battery Construction

Component	Positive plate	Negative plate	Container	Cover	Safety valve	Terminal	Separator	Electrolyte
Raw material	Lead dioxide	Lead	ABS	ABS	Rubber	Copper	PVC	Gelled acid

### General Features

- Nanometer SiO<sub>2</sub> and H<sub>2</sub>SO<sub>4</sub> gelled electrolyte technology for efficiency gas recombination of up to 99% and freedom from electrolyte maintenance or water adding.
- Not restricted for air transport-complies with IATA/ICAO Special Provision A67.
- UL-recognized component.
- Can be mounted in any orientation.
- Computer designed lead, calcium tin alloy grid for high power density.
- Long service life, float or cyclic applications.
- Maintenance-free operation.
- Low self discharge.
- Case and cover available in both standard and flame restardant ABS.

### Dimensions and Weight

Length(mm / inch)	710 / 27.95
Width(mm / inch)	350 / 13.78
Height(mm / inch)	345 / 13.58
Total Height(mm / inch)	382 / 15.04
Approx. Weight(Kg / lbs)	190 / 419

\* Weight deviation: ± 3%

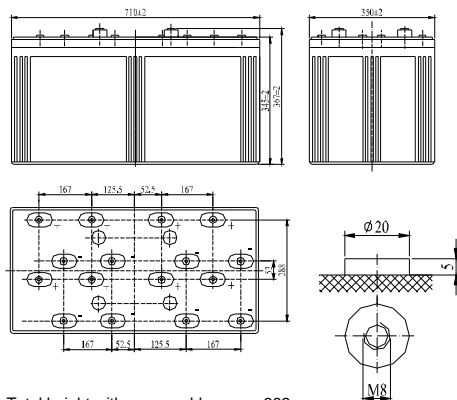

Total height with removeable cover: 382

### Performance Characteristics

Nominal Voltage	2V
Number of cell	1
Design Life	20 years
Nominal Capacity 77°F(25°C)	
10 hour rate (300A, 1.80V)	3000Ah
5 hour rate (528A, 1.75V)	2640Ah
1 hour rate (1860A, 1.6V)	1860Ah
Internal Resistance	
Fully Charged battery 77°F(25°C)	≤ 0.55mOhms
Self-Discharge	
2% of capacity declined per month at 20°C(average)	
Operating Temperature Range	
Discharge	-20~60°C
Charge	-10~60°C
Storage	-20~60°C
Max. Discharge Current 77°F(25°C)	6500A(5s)
Charge Methods: Constant Voltage Charge 77°F(25°C)	
Cycle use Charge Voltage:	2.40-2.45VPC
Maximum charging current	600A
Temperature compensation	-5mV/°C
Standby use	2.20-2.30VPC
Temperature compensation	-3.3mV/°C

### Discharge Constant Current (Amperes at 77°F25°C)

End point volts/cell	10min	15min	30min	1h	3h	5h	10h	20h
1.60V	6300	5160	3000	1860	780	570	315	168
1.65V	5940	4800	2940	1800	760	552	312	165
1.70V	5580	4560	2880	1740	740	540	306	162
1.75V	5220	4200	2820	1680	730	528	303	161
1.80V	4860	3840	2700	1590	700	510	300	158

### Discharge Constant Power (Watts at 77°F25°C)

End point volts/cell	10min	15min	30min	1h	3h	5h	10h	20h
1.60V	10786	8751	5616	3482	1460	1094	610	331
1.65V	10264	8678	5363	3312	1386	1033	554	312
1.70V	9999	8317	5115	3174	1314	985	543	298
1.75V	9521	7795	4963	3064	1250	963	524	288
1.80V	9020	7373	4752	2926	1176	898	490	277

(Note) The above characteristics data are average values obtained within three charge/discharge cycles not the minimum values. All data shall be changed without notice, LUXURY reserves the right to explain and update the information contained hereinto.

