

# CT12-150X 12V150Ah(10hr)

The rechargeable batteries are lead-lead dioxide systems. The dilute sulfuric acid electrolyte is absorbed by separators and plates and thus immobilized. Should the battery be accidentally overcharged producing hydrogen and oxygen, special one-way valves allow the gases to escape thus avoiding excessive pressure build-up. Otherwise, the battery is completely sealed and is, therefore, maintenance-free, leak proof and usable in any position.

## Battery Construction

Component	Positive plate	Negative plate	Container	Cover	Safety valve	Terminal	Separator	Electrolyte
Raw material	Lead dioxide	Lead	ABS	ABS	Rubber	Copper	Fiberglass	Sulfuric acid

## General Features

- Absorbent Glass Mat (AGM) technology for efficient gas recombination of up to 99% and freedom from electrolyte maintenance or water adding.
- Not restricted for air transport-complies with IATA/ICAO Special Provision A67.
- UL-recognized component.
- Can be mounted in any orientation.
- Computer designed lead, calcium tin alloy grid for high power density.
- Long service life, float or cyclic applications.
- Maintenance-free operation.
- Low self discharge.
- Case and cover available in both standard and flame retardant ABS.

## Dimensions and Weight

Length(mm / inch)	548 / 21.6
Width(mm / inch)	105 / 4.13
Height(mm / inch)	316 / 12.4
Total Height(mm / inch)	316 / 12.4
Approx. Weight(Kg / lbs)	48.8 / 107.7

\* Weight deviation: ± 3%

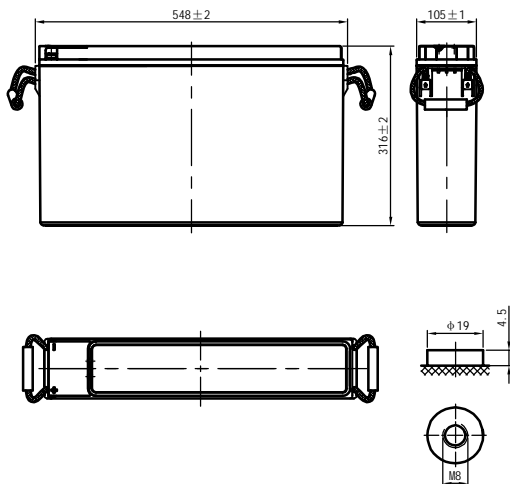

## Performance Characteristics

Nominal Voltage	12V
Number of cell	6
Design Life	10 years
Nominal Capacity 77°F(25°C)	
10 hour rate (15.0, 10.8V)	150Ah
5 hour rate (28.4A, 10.5V)	142Ah
1 hour rate (111A, 9.6V)	111Ah
Internal Resistance	
Fully Charged battery 77°F(25°C)	≤4.5mOhms
Self-Discharge	
3% of capacity declined per month at 20°C(average)	
Operating Temperature Range	
Discharge	-20~60°C
Charge	-10~60°C
Storage	-20~60°C
Max. Discharge Current 77°F(25°C)	1050A(5s)
Short Circuit Current	2680A
Charge Methods: Constant Voltage Charge 77°F(25°C)	
Cycle use	2.40-2.45VPC
Maximum charging current	45A
Temperature compensation	-30mV/°C
Standby use	2.20-2.30VPC
Temperature compensation	-20mV/°C

## Discharge Constant Current (Amperes at 77°F25°C)

End Point Volt/Cell	10min	15min	30min	45min	1h	3h	5h	10h
1.60	310	270	178	137	111	47.1	30.2	15.4
1.65	285	252	171	133	109	46.2	29.6	15.3
1.70	260	233	164	129	106	45.3	29.0	15.2
1.75	235	214	157	125	103	44.4	28.4	15.1
1.80	210	195	149	120	99.9	43.4	27.8	15.0

## Discharge Constant Power (Watts at 77°F25°C)

End Point Volt/Cell	10min	15min	30min	45min	1h	3h	5h	10h
1.60	498	432	298	230	190	88.1	57.6	29.6
1.65	479	420	292	227	188	87.2	57.1	29.4
1.70	460	407	286	223	186	86.3	56.5	29.2
1.75	440	394	280	219	184	85.3	55.9	29.0
1.80	420	381	273	215	181	84.3	55.3	28.8

(Note)The above characteristics data are average values obtained within three charge/discharge cycles not the minimum values. All data shall be changed without notice,Luxury reserves the right to explain and update the information contained hereinto.

