

# HFS12-800WS-X

## FEATURES

- Maintenance free(no water topping-up required)
- No free acid(Non-spillable battery)
- Low self-discharge rate, lower than 3% capacity loss per month
- Gas recombination efficiency over 99%
- Computer designed lead, Pure lead grid for high power density.
- The battery is designed for high rate usage

## Application Fields

- Office Machines and Computers
- Telecommunications
- UPS Equipment
- Electrical facilities
- Vending machine

## SPECIFICATIONS

Nominal Voltage	12 V
Nominal Capacity	800W/cell @ 15 min rate F.V.(1.67V/cell)
Approx. Weight	67.5Kg(80.5 lbs) (Weight deviation: ± 3%)
Internal Resistance	≤2.5mΩ (Fully Charged )
Max. Discharge Current	1000 A (5 sec.)
Max. Charge Current	60 A
Operating Temperature Range	Charge : -10°C~50°C Discharge : -20°C~60°C Storage. : -20°C~60°C
Container Material	ABS



## Dimensions

	SI Units	English Units
Length	522mm	20.55inch
Width	238mm	9.37inch
Height	218mm	8.58inch
Total Height	223mm	8.78inch

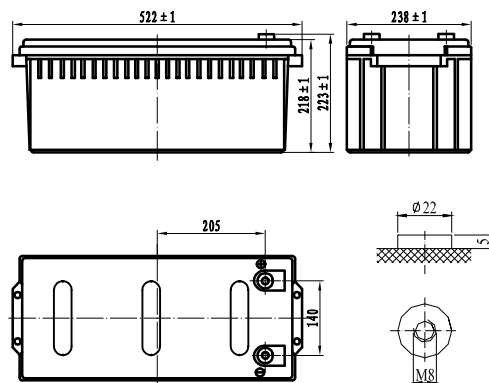

## Constant Current Discharge( Amperes at 25 °C)

End Point Volts/cell	10min	15min	20min	30min	45min	60min
1.60	570	440	357	252	184	145
1.67	523	411	329	232	171	135
1.75	476	381	301	213	157	125
1.80	459	360	292	207	153	122

## Constant Power Discharge( Watts at 25 °C)

End Point Volts/cell	10min	15min	20min	30min	45min	60min
1.60	1034	834	669	470	336	270
1.67	977	800	635	448	321	259
1.75	918	767	601	425	306	248
1.80	880	744	578	409	296	240

(Note)The above characteristics data are average values obtained within three charge/discharge cycles not the minimum values. All data shall be changed without prior notice, **LUXURY** reserves the right to explain and update the information contained hereinto.